

## BACnet Commercial Thermostat

RDY2000BN



**Powerful. Versatile. Designed for light commercial HVAC systems applications. Ideally suited for schools, medical and financial offices, retail establishments, restaurants, and light manufacturing facilities. Now communicating on BACnet.**

- BTL listed MS/TP ensures compatibility with any BACnet system.
- Built-in flexible control programs for conventional and heat pump applications.
- Controls conventional systems with up to 3 stages heating and 3 stages cooling.
- Controls heat pumps with 1 or 2 compressors and up to 2-stage auxiliary heat.
- On-board temperature and humidity sensor.
- Multiple configurable inputs and outputs enable advanced control strategies.
- Set-up Wizard enables rapid system configuration.
- No special tools required for installation or commissioning.
- Seven-day (2- or 4-event) occupancy scheduling.
- Sleek design with backlit 5-inch LCD touchscreen.

## Features

### Hardware

- Standard 24 Vac HVAC interface:
  - Y1, Y2, G, W1, W2 and O/B
- Three selectable relay outputs
- Four configurable inputs:\*
  - Digital input
  - Resistive temperature input
  - 0 to 10V input

\*Requires purchase of external sensor(s).

### Control

- BTL-listed BACnet MS/TP.
- Fully-programmable 7-day, 2-, 4-, or 6-event occupancy scheduling function.
- Real-time clock retains time and date for up to 48 hours upon loss of input power.
- System configuration data is stored indefinitely upon loss of input power.
- Interlocks and timers specifically designed for equipment protection.
- Password protected installer set-up menu deters unauthorized changes.
- Programmable fan enables fresh air circulation when not in heating/cooling mode.
- Selectable lockout levels to minimize tampering with setpoints and schedule.
- Programmable service reminders for humidifier pad, UV lamp, and air filter.

### General

- Separable back plate with wiring terminals and mounting holes configured to match most conduit box configurations (screws and anchors included for drywall mounting).
- Thermostat secures to mounting base with screws to deter theft and vandalism.
- Designed for horizontal layout.

## Applications

- Designed for light commercial HVAC systems with 24 Vac control circuitry.
- Compatible with forced air, hydronic and steam systems fired by gas, oil or electricity.
- Controls conventional systems with up to 3 stages heating and 3 stages cooling.
- Controls heat pumps with 1 or 2 compressors and up to 2-stage auxiliary heat.
- Built-in temperature and humidity sensor in addition to configurable inputs enables advanced room controls based on humidity, CO<sub>2</sub>, occupancy, remote or averaging temperature.
- Selectable relays enable control strategies for humidity/dehumidification control, ventilation, economizer enable and occupancy notification.

## Type summary

Part Number	Description
RDY2000BN	BACnet Commercial Thermostat

## Accessories

Part Number	Description
QAA2230.EWNN	Remote Wall Mounted Sensor – Temperature Only
QFA32SS.EWNN	Remote Wall Mounted Temperature and Humidity Sensor
QAM2030.010	Duct Mounted Temperature Sensor

Part Number	Description
QFM2160U	Duct Mounted Temperature and Humidity Sensor
QPA2000	Wall Mounted CO2 Sensor
QPA2062	Wall Mounted Temperature + Humidity + CO2 Sensor
QPM2162	Duct Mounted Temperature + Humidity + CO2 Sensor
QAC2030	Outdoor Air Temperature Sensor
QAD2030	Surface Mount Pipe Temperature Sensor

## Product documentation

Topic	Title	Document ID:
Installation Instructions	RDY2000BN BACnet Enabled Commercial Room Thermostat	125-1009
Application Note	RDY2000BN BACnet Thermostat Heat Pump Application 14901	140-1230
Application Note	RDY2000BN BACnet Thermostat Conventional Application 14900	140-1231
WCIS Online Help	User's Guide: Setup & Service Assistant (SSA)	N/A

## Technical data

Power supply	
Operating voltage	24 Vac ± 20%, Class 2, 4A maximum
Frequency	50/60 Hz.
Power consumption including connected field devices	Max. 96 VA
24 Vac supply for field devices	
Output relay ratings	Pilot duty, 1A maximum per output, 4A maximum total
Ambient conditions and protection classification	
Enclosure	NEMA 1
Transport	Temperature -13°F through 158°F (-25°C through 70°C) Air humidity up to 95% (non-condensing)
Operation	Temperature 23°F through 122°F (-5°C through 50°C) Air humidity Up to 95% (non-condensing)
Setpoint range	45°F through 95°F (7°C through 35°C)
Standards, directives and approvals	
UL	UL 916
cUL	CSA C22.2 No. 205
CE	EMC Directive
ICES	Canada
NOM-NYCE	Mexico
Regulatory Compliance Mark	Australia
Federal Communications Commission	Complies with the limits for a Class B digital device, pursuant to Part 15 of the FCC rules.
BTL	BACnet Testing Laboratory
Miscellaneous	
Shipping weight	14 ounces (0.4 kg)

## Dimensions

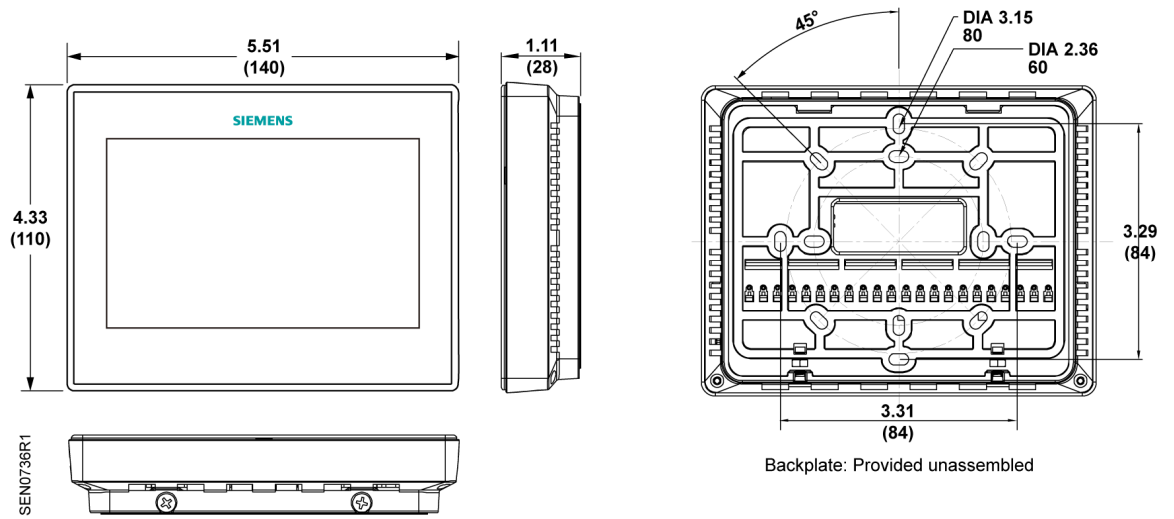

*Dimensions in Inches (mm).*